

GIZMO ENGINEERING CONTROL DRAWING FOR MODEL IS-AB, IS-T, AND IS-D

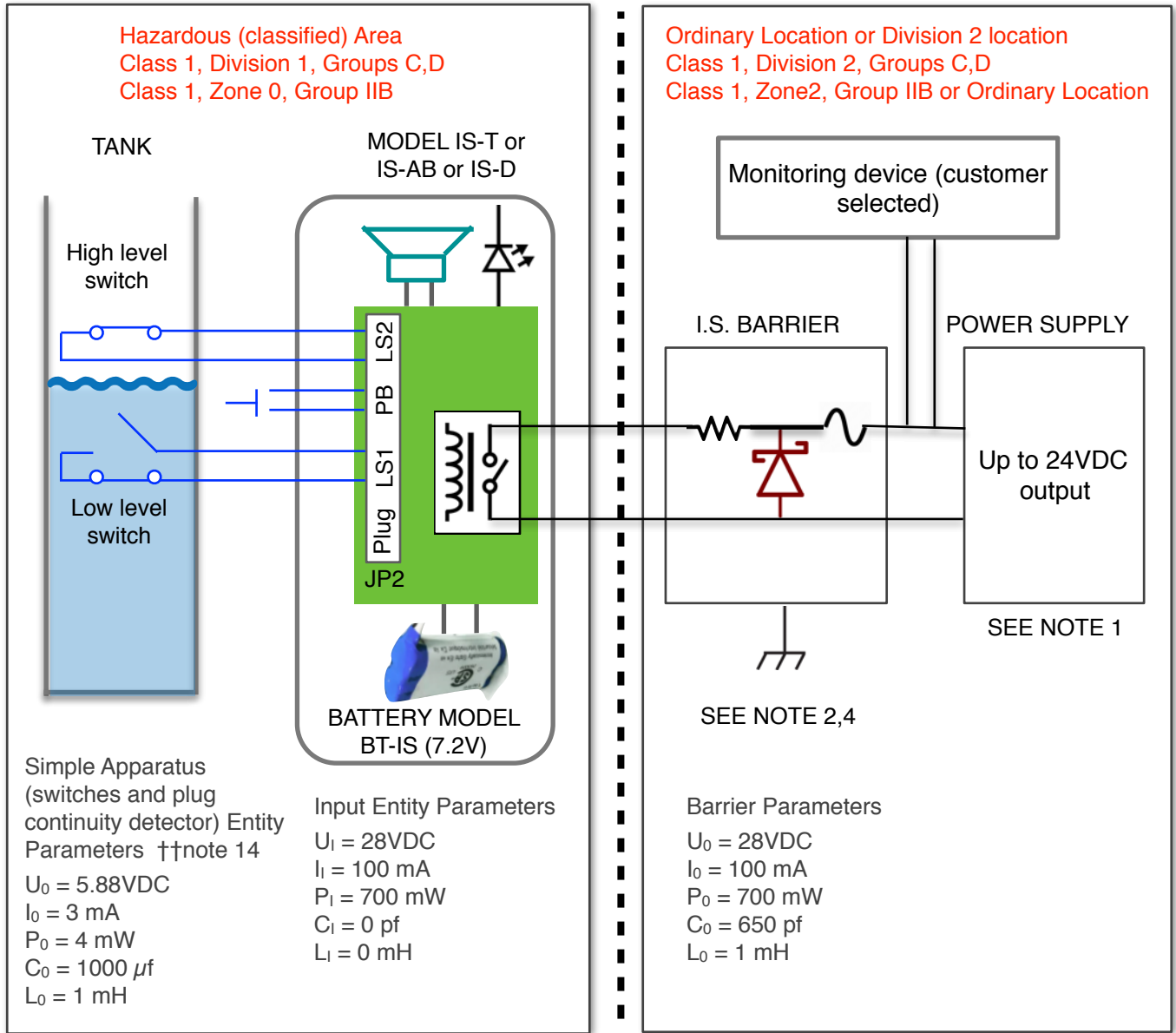

Associated apparatus and nonincendive associated field wiring apparatus parameters	Condition that must be satisfied	Intrinsically safe and nonincendive field wiring apparatus parameters
V_{oc} or U_0	\leq	V_{max} or U_I
I_{sc} or I_0	\leq	I_{max} or I_I
P_0	\leq	P_i
C_0 or C_a	\geq	C_i
L_a or L_0	\geq	L_i
C_I plus C_{cable} must be less than C_0		
L_I plus L_{cable} must be less than L_0		

TITLE: Control Drawing		FILE: Control Drawing IS-001	
AUTHOR: Peter Blokhuis, Gizmo Engineering	Rev 4	Jan 23, 2019	Page 1 of 2

GIZMO ENGINEERING CONTROL DRAWING FOR MODEL IS-AB, IS-T, AND IS-D

NOTES

1. Maximum safe area voltage is 250V.
2. The associated apparatus (barrier) must be connected to a suitable ground electrode per the National Electrical Code (NFPA 70) the Canadian Electrical Code, or other installation codes, as applicable by the authority having jurisdiction. (AHJ)
3. Tank float switches, push-button, and continuity wire in Division 1/Zone 0 are Simple Apparatus.
4. The resistance of the ground path must be less than 1 Ω .
5. Intrinsically safe circuits must be wired and separated in accordance with Article 504.20 of the National Electrical Code (ANIS/NFPA 70) or other local codes, as applicable.
6. The associated apparatus has not been evaluated for use in combination with another associated apparatus.
7. This drawing may not be altered without notice to the certification body.
8. Battery package is Intrinsically Safe and may be replaced in the Hazardous Location.
9. Only Intrinsically Safe battery package BT-IS must be used with models IS-AB, IS-T, or IS-D.
10. Float switches, Plug Continuity circuit and Push Button switch are all derived from the same circuit and operate at extremely low power, and separation per NEC 504.30 (B) is not required because combined energy from all 4 circuits is Intrinsically Safe. Intrinsically Safe circuits in connector JP2 must be separated from the the Barrier Protected Intrinsically Safe circuit of RY1 by at least 6 mm (0.25 inch)
11. Environmental Conditions: Outdoor, -40°C to +60°C, 2000m max.
12. The enclosure of IS-T and IS-D are made from aluminum. In rare cases ignition sources due to impact and friction sparks could occur. This shall be considered during installation. Use care not to cause impacts or scrapes with other metal objects during installation.
13. Under certain extreme circumstances, exposed plastics and unearthed metal parts of the enclosure of models IS-AB, IS-T, IS-D may store an ignition capable of an electrostatic charge. Therefore the user/installer shall implement provisions to prevent the buildup of electrostatic charge, i.e. locate the equipment where a charge-generating mechanism is unlikely to be present, and clean only with a water-moistened cloth.

††

14. Simple apparatus switches in other applications (flow, go or no-go, etc.) are permitted with all models IS-AB, IS-T, IS-D provided that the customer verifies that the Simple Apparatus switches are used within their ratings, and that the Entity Parameters are correctly applied. The Simple Apparatus switches will not form part of the Drum Alarm devices.

TITLE: Control Drawing	FILE: Control Drawing IS-001		
AUTHOR: Peter Blokhuis, Gizmo Engineering	Rev 4	Jan 23, 2019	Page 2 of 2